

# Coffered Direct Fix Tile Installation + Care

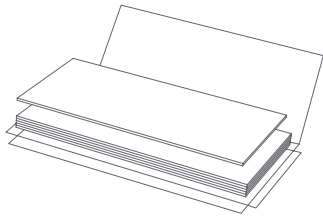

## Supplied



Ecoustic Panels  
3 per set (Coffered 100)  
2 per set (Coffered 50)

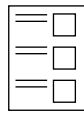

Instructions

## Essential

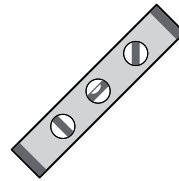

Spirit level



Clean hands

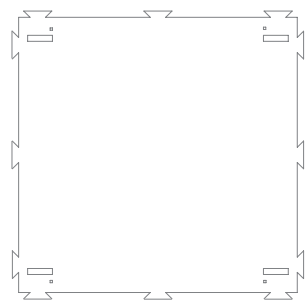

Back Panel  
8 x (Coffered 100)  
7 x (Coffered 50)

 U Shape Cleats  
32 x

 1mm Spacer  
4 x

 10mm T Spacer  
2 x

 10mm Corner Spacer  
2 x

 10mm Corner Spacer  
2 x

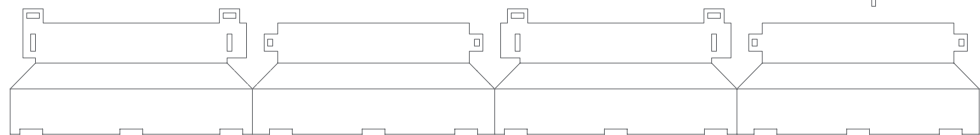

Frame  
8 x (Coffered 100)  
7 x (Coffered 50)

## Step 1

On a clean flat surface remove the components from their protective surrounds, separating the different components. Remove excess material from fold lines, tabs and assembly slots

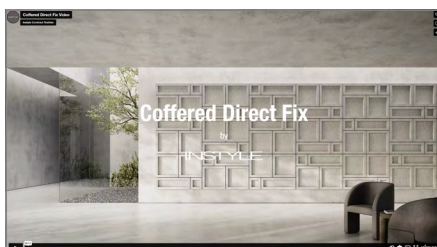
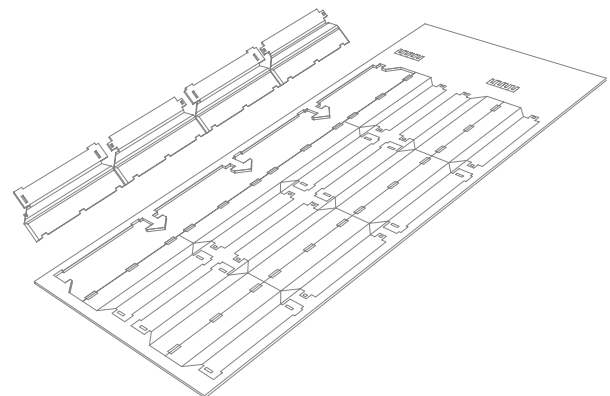
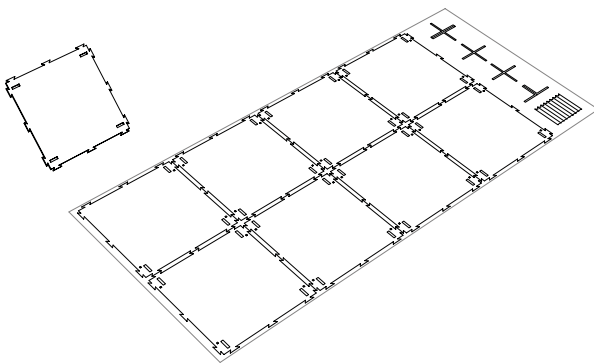

### INSTALLATION VIDEO

**Coffered Direct Fix Installation Video** is available on our website

## Step 2

Fold the flanges upwards along the fold grooves to create a channel with the opening facing upwards.

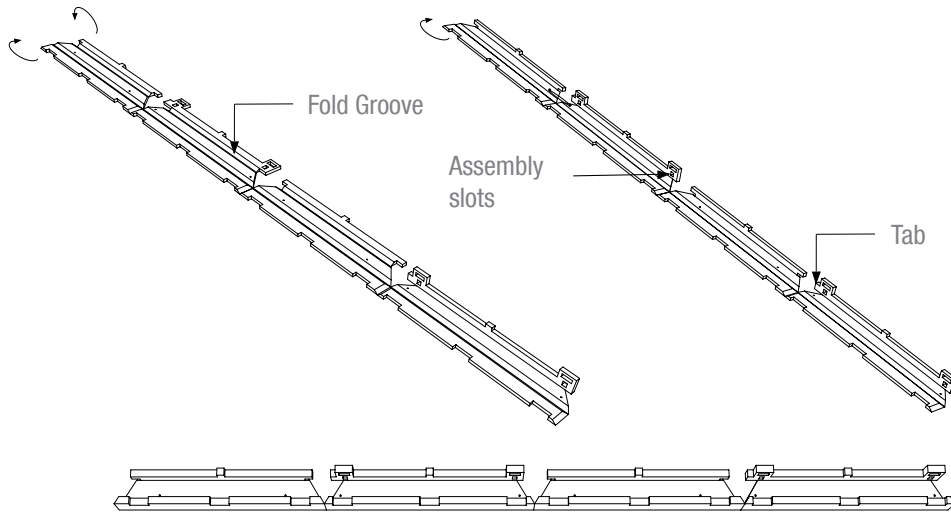

## Step 3

Fold each side of the body channels assembly 90 degree along the vertical V-Groove joints and engage the tab into the assembly slot of the adjoining side.

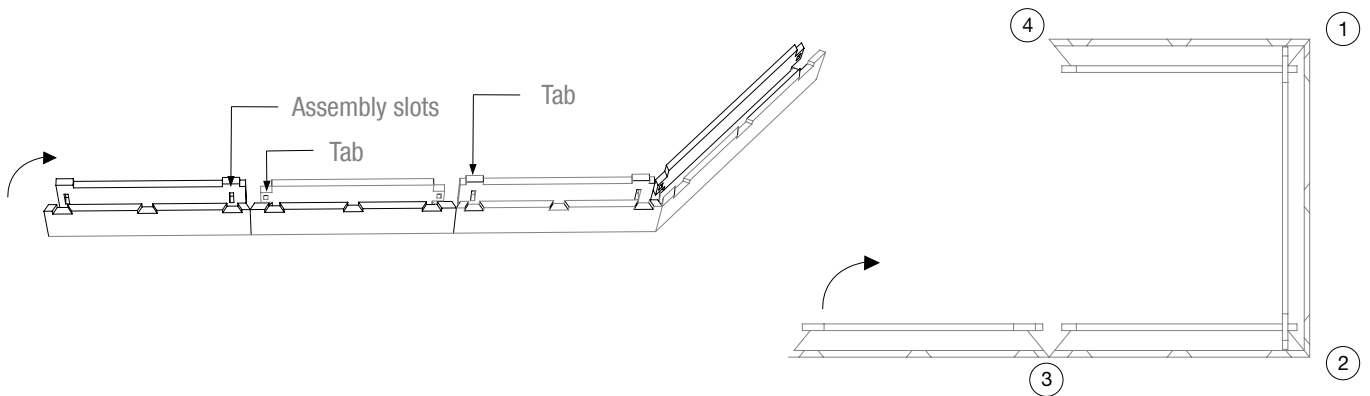

## Step 4 - 100mm Depth Tiles

Insert 'U' shaped cleats through the tabs to stop the tabs from slipping out (100mm depth tiles). The 'U' shaped cleats are to be inserted into all 4 corner junctions of the 100mm deep assembly

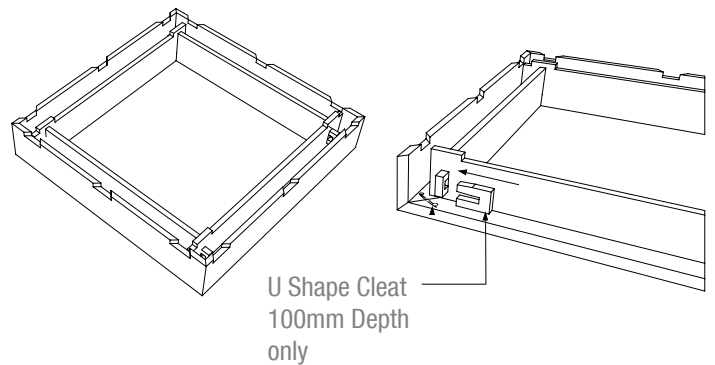

## Step 5A - Without Edge Trim

Measure and mark out final location of tile installation on wall using a spirit level or similar to create removable installation reference lines and securely fix back panel to wall through dedicated mounting holes. The folded tile assembly will conceal any fixings.

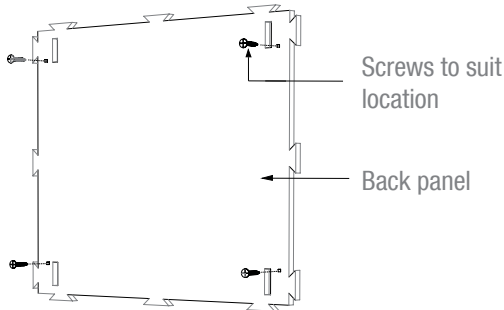

## Step 6A - Without Edge Trim

For multiple tiles, repeat step 5 using a spirit level to ensure installation is level. Install back panels first before adding the folded tile assembly. Position adjacent panels using the corner spacers provided to create either 10mm void or 1mm void between tiles.

Back panels with 10mm spacers to create 10mm void between tiles

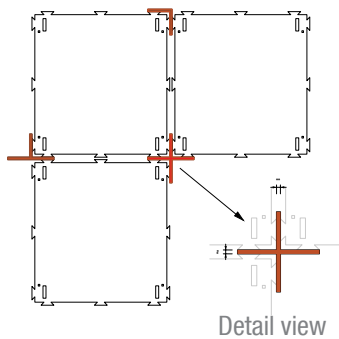

Back panels with 1mm spacers to create 1mm void between tiles

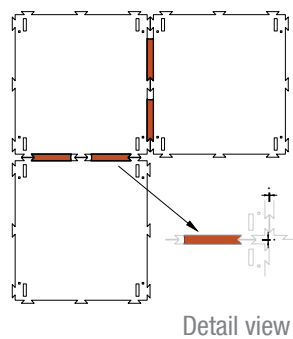

## Step 7A - Without Edge Trim

Manoeuvre the folded tile frame assembly over the backing panel. Rotate the tile frame to position the frame corner connected last during the assembly process (4) close to the installers view. Fit the frame corner (4) into the backing panel and apply soft pressure on the edges to engage the dovetail joints. Repeat with the remaining 3 corners of the tile frame. Follow the same sequence for each tile until installation is complete.

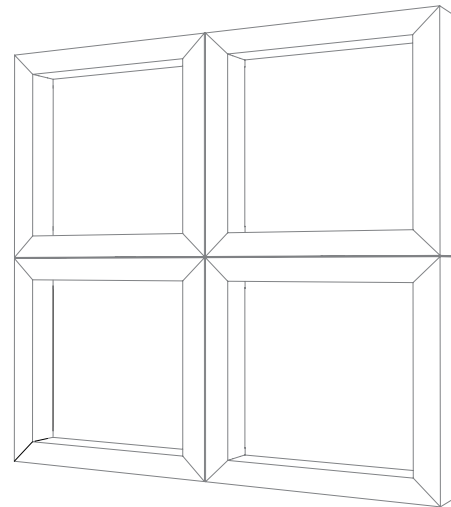
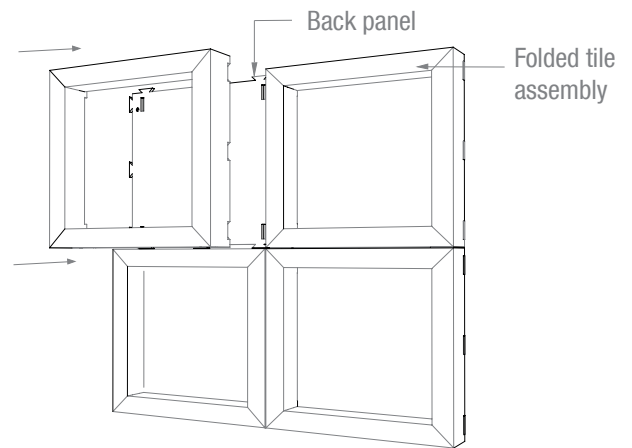

## Step 5B - With Edge Trim

Measure and mark out final location of tile installation on wall using a spirit level or similar to create removable installation reference lines and securely fix back panel to wall through dedicated mounting holes. The folded tile assembly will conceal any fixings, then securely fix edge trim to wall. Mitre corner joints and ensure edge trims are level and straight.

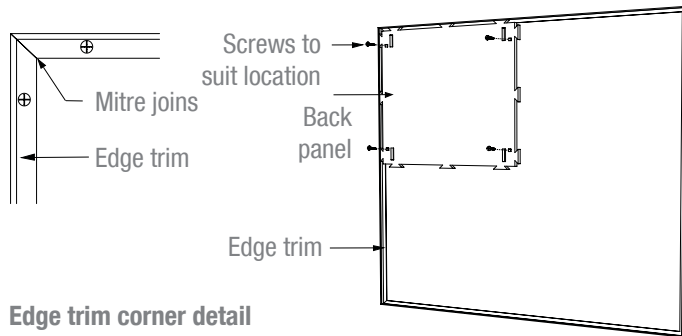

Edge trim corner detail

## Step 6B - With Edge Trim

Securely fix back panel to wall using dedicated mounting holes. The folded tile assembly will fully conceal any fixings. For multiple tiles repeat Step 5b, install back panels first before adding the folded tile assembly. Position adjacent panels using the corner spacers provided to create either 10mm void or a 1mm void between tiles.

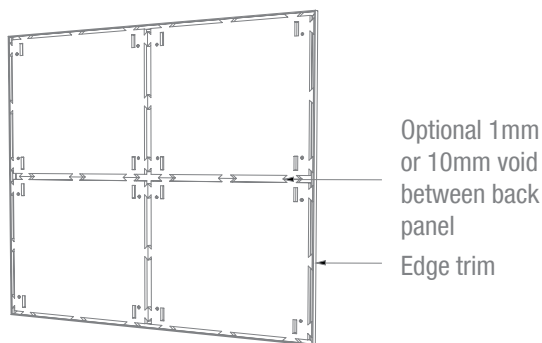

## Step 7B - With Edge Trim

Manoeuvre the folded tile frame assembly over the backing panel. Rotate the tile frame to position the frame corner connected last during the assembly process (4) close to the installers view. Fit the Frame corner (4) into the backing panel and apply soft pressure on the edges to engage the dovetail joints. Repeat with the remaining 3 corners of the tile frame. Follow the same sequence for each tile until installation is complete.

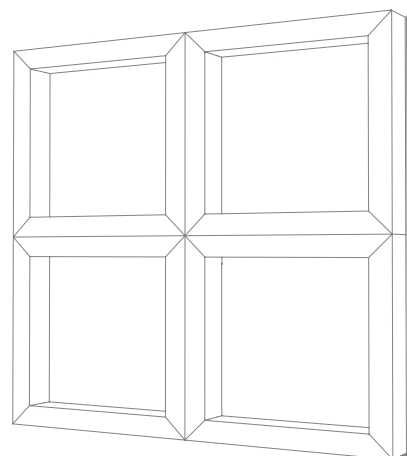
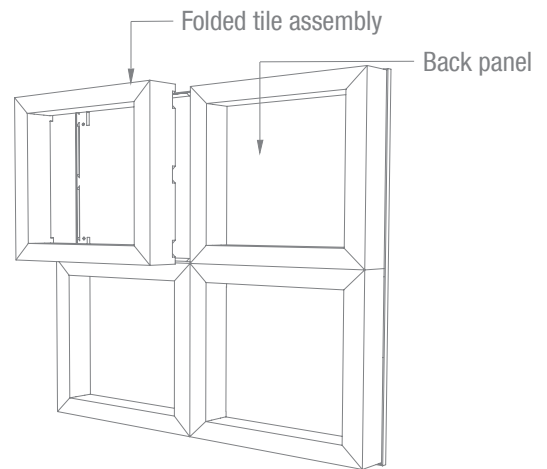
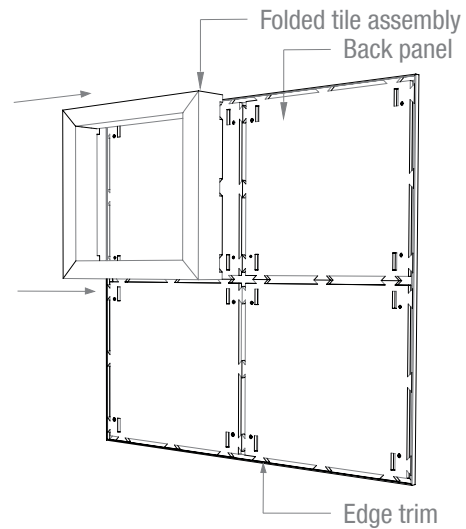

## Regular Care

- Protect from direct heat and sunlight
- To prevent dust build up, lightly dust with a soft cloth or vacuum with a soft brush attachment

## Cleaning

- Professional cleaning is always recommended
- Always test any any cleaning products on an inconspicuous area prior to commencing cleaning
- Blot any excess spills from the material with a dry clean sponge or cloth
- Treat all stains and spills as soon as possible
- Most marks can be spot cleaned by lightly wetting the affected area with a mild detergent and warm water solution
- Do not saturate the tile
- Do not scrub or abrade the surface as this will affect the surface finish
- Once the stain or mark has been loosened then blot the excess solution out with a dry clean sponge or cloth
- Sponge afterwards with clean warm water and dry any excess moisture with a dry clean sponge or cloth
- The product can also be spot cleaned with dry cleaning fluid, lightly sponge a small amount of dry cleaning fluid and blot
- Dry away from direct heat and sunlight
- Do not use carpet shampoo